

# AOPico Montauk Series

Industrial IR picosecond laser

- High pulse energy up to 2mJ
- Burst mode
- Pulse-on-demand
- Glass processing
- Single pulse can be adjusted
- Multiple control modes
- Power range up to 90W
- Cutting thickness range is wide



## ► Features & Benefits:

The all-in-one design makes the laser more compact and reduces the total weight. It saves space for installation on the customer side, lowers the integration cost and simplifies the installation process. The water-cooled design allows the laser to work reliably in various harsh and extreme environments and makes the laser to be the ideal candidate for the 7x24 non-stop production needs.

The output power of 10W, 20W, 30W, 45W and up to 70W are available for selection. The pulse width is around 10 ps across the repetition rate range of 100k to 1000k. With pulse energy up to 2 mJ, burst mode and PoD function, it is the perfect candidate for transparent and brittle material cutting, including glass, sapphire, phone screen, and so on. It can achieve excellent cutting quality (almost no dust, no chipping, micro-cracks), high bending strength, and taper-free arbitrary shapes.



Sapphire cutting

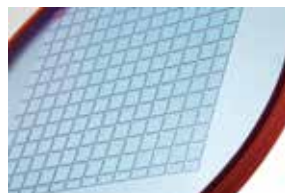

Glass cutting



Metal etching



Full-screen cutting

Typical Performance AMT-1064-15W

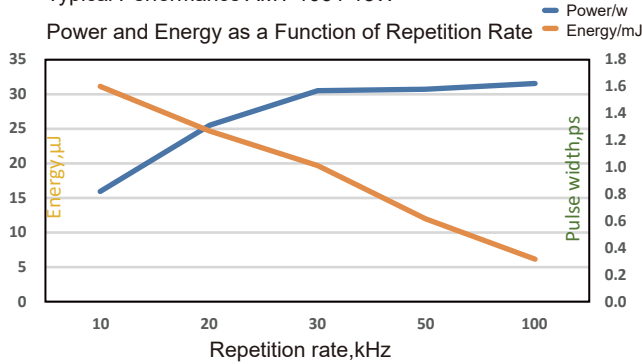

Typical Performance AMT-1064-20W/30W

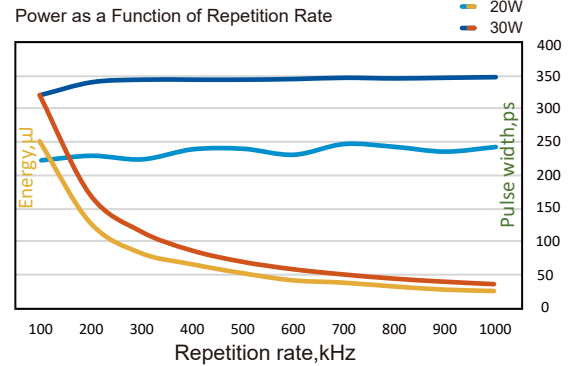

Typical Performance AMT-1064-50W

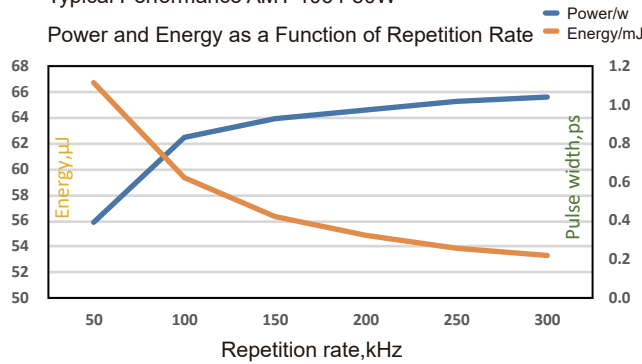

Typical Performance AMT-1064-60W

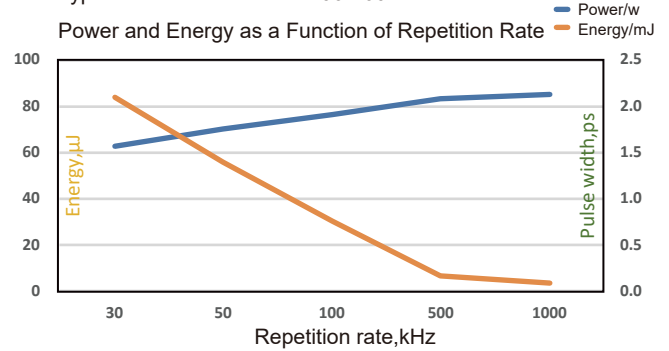

AOPico Montauk 1064

Specification	15W-10K	20W-100K	30W-100K	50W-50K	60W-30K
Wavelength (nm)	1064				
Average Power (Watts)	>15	> 20	>30	>50	>60
Energy (µJ)	1500@10KHz	200@100KHz	300@50KHz	1000@50KHz	2000@30KHz
Specified Repetition Rate(kHz)	10	100	100	50	30
Repetition Rate (kHz)	10~100	100~1000	100~1000	50~300	30~1000
Pulse Width (ps)	<12				
Beam Quality (M <sup>2</sup> )	<1.5	<1.2	<1.3	<1.3	<1.5
Beam Roundness (%)	>90				
Beam Diameter (mm)	<3				
Beam Divergence (mRad)	<2				
Point Stability (µrad/°C)	<20				
Polarization Ratio	100:1 Linear, Horizontal				
Pulse-to-Pulse Stability (% RMS)	<2				
Average Power Stability(% over12 hours)	<3				
Cold Start Warm-Up (mins.)	<40				
Standby Warm-Up (mins.)	<10				
Operational Temperature Range (°C)	15-35°C				
Operation Humidity Range (%)	20 to 80,non-condensing				
Storage Temperature Range (°C)	- 20 to 50				
Storage Humidity Range (%)	20 to 80,non-condensing				
Input Voltage (VDC)/Rated Power(W)	24/600			24/1000	
Communication	RS232				
Cooling	Water				

# AOPico Montauk SERIES

AOPico Montauk 1064 -15W、20W、30W Laser Size

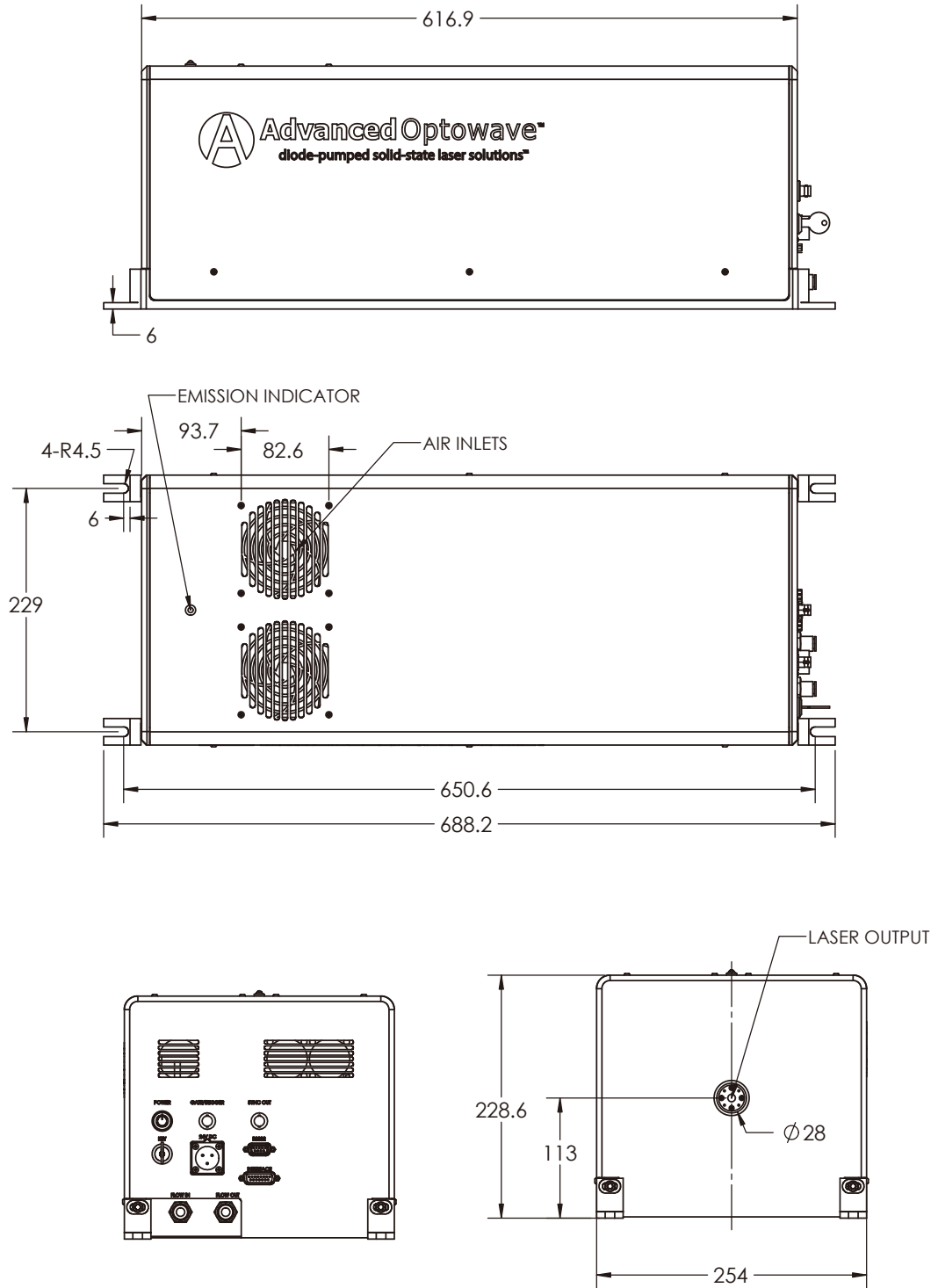

**AOPico Montauk-1064-15W/20W/30W**

AOPico Montauk 1064 -50W、60W、70W Laser Size

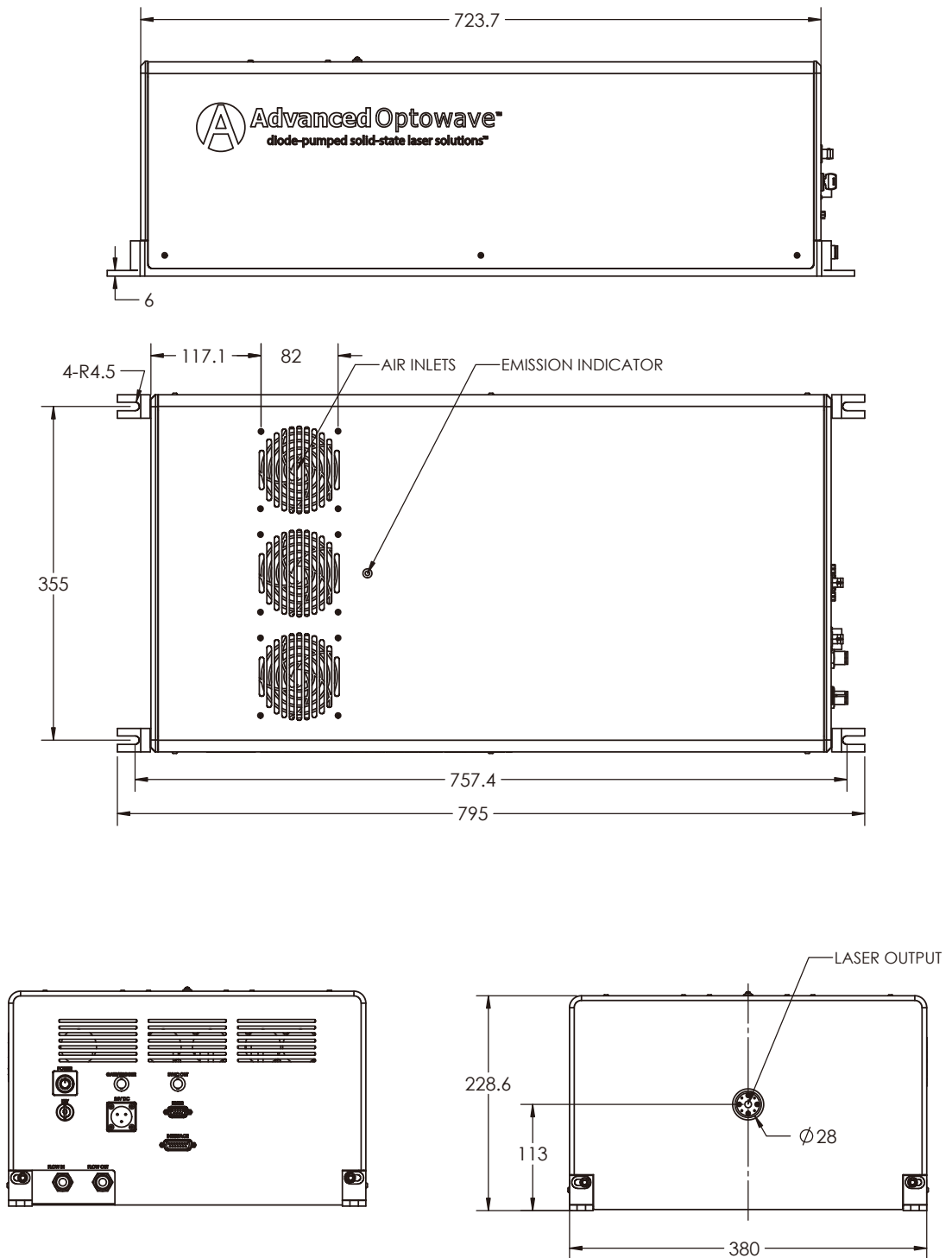

**AOPico Montauk-1064-50W/60W/70W**